

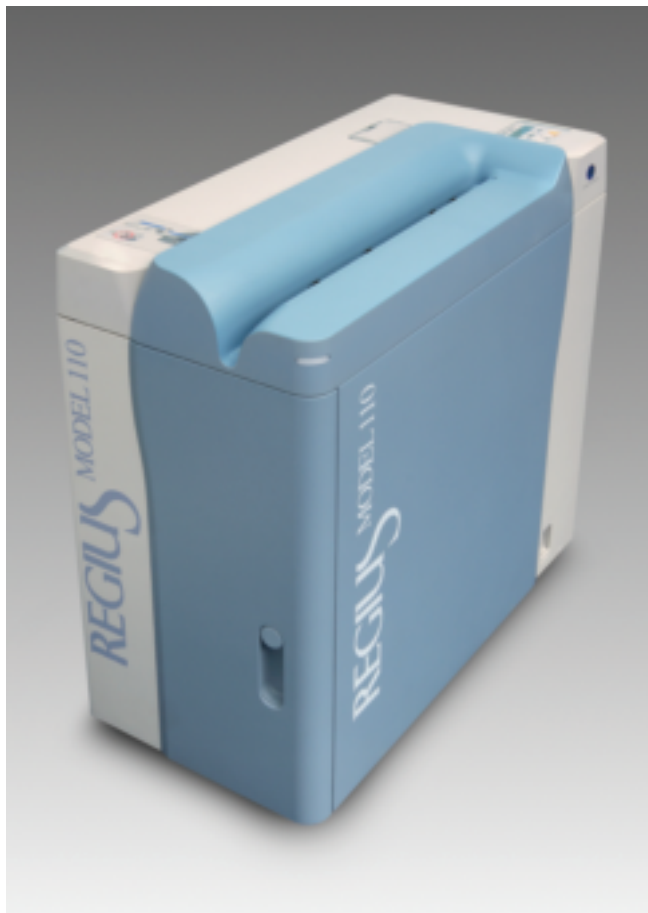

KONICA MINOLTA

REGIUS NANO CR – P Class The Private Physician Solution



Go Digital... It's Quick, Easy and Affordable!

Now you can convert your private practice to digital radiography with the REGIUS NANO CR system. It is a high performance system that offers compact size and dependability! Processing 60 (14" x 17") plates per hour, the NANO CR lets you take care of more patients in less time.

The Nano CR features intelligent control station software with auto recognition and self learning capabilities. You will be able to generate high quality diagnostic images with minimal training and fewer steps for improved workflow.

Features and Benefits

- A 2-view exam can be completed in less than one minute
- Cassette release handle allows user access to remove a jammed cassette... no service call necessary!
- Intelligent systems adjust image quality to your preference
- Dual reader orientation option for customized space utilization
- Optical unit sweeper enables self-maintenance for pristine image quality and longer product lifetime
- Our patented, rigid image plate is contact free within the CR Reader eliminating the potential for image artifacts and extends the life of the plate.

Everything you need in one package!

- Superior image quality right out of the box
- Space saving cart is included. Houses all components of the Nano P Class.
- Four standard sized cassettes and plates are included for your convenience.

NANO CR

The Physician Solution

The essentials of imaging

“Going Digital” with NANO CR - P Class

The value of “Going Digital” is well known. The benefits include the elimination of wet processing chemicals, the reduction of retakes and the consistent production of high quality images. However, users may often be concerned with the learning curve often associated with new technology adoption. Nano CR eliminates these concerns. The built in intelligence of this system allows first-time users of Computed Radiography to produce consistent, high quality images out of the box with minimal instruction.

Nano CR Reader Specifications*

Exposure Size	14 x 17", 14 x 14", 11 x 14", 10 x 12", 8 x 10", 18 x 24cm, 24 x 30cm, 15 x 30cm
Maximum Resolution	2010 x 2446 (14 x 17")
Digital Gradation Level	4096 levels (12 bit)
Processing Capacity	Approximately 60 plates an hour (14 x 17")
Cycle Time	Approximately 59 seconds (14 x 17")
Outer Dimensions / Weight	W29.1" x D14.4" x H29.4" / Approximately 220 lbs.
Power Consumption	AC 100/115/120/200/220/230/240V ±10%; 50/60 Hz; Approx. 700 VA or less
Operating Conditions	Temperature: 15°C – 30°C Humidity: 35% – 80% RH (no condensation)

*Specifications are subject to change without notice

Control Station Specifications*

DICOM Services	DICOM Storage (CR/DX SCU) or DICOM Print SCU DICOM Modality Worklist SCU DICOM Grayscale Standard Display Function SCU DICOM Modality Performed Procedure Step SCU DICOM Grayscale Standard Presentation State SCU DICOM Storage Commitment SCU
Image Output	Up to 2 DICOM Store Plus 1 Backup Up to 1 DICOM Print Plus 1 Backup
Image Processing	Automatic Gradation Processing (G processing) Frequency Processing (F processing) Equalization Processing (E processing) Hybrid Processing (H processing)
Image Storage Capacity	Approximately 5,000 images
Dimensions	PC: 7.2"(W) x 15.8"(D) x 14.5"(H) Touch Screen: 15.0"(W) x 20.3"(H) x 8.2"(D)
Weight	PC: 25 lbs.; Touch Screen: 18 lbs.
Power Source	PC: AC 100–240V; 50/60 Hz Touch Screen: AC 100–240V; 50/60 Hz
Heat Generation	PC: Approximately 160 Watts or 548.8 BTU Touch Screen: 40 Watts or 136 BTU
Operating Conditions	Temperature: 15°C – 35°C Humidity: 40% – 80% (non condensing)

*Specifications are subject to change without notice.

Outer Dimensions

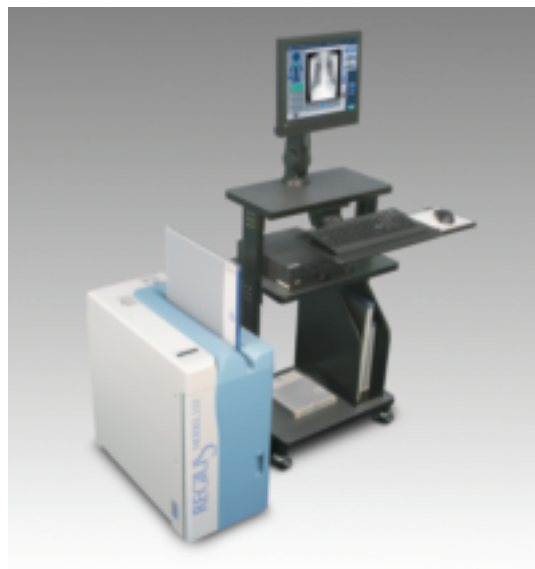
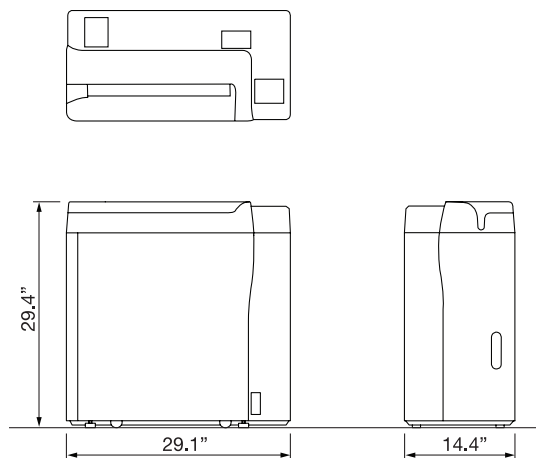

Konica Minolta's Commitment to Customer Satisfaction

At Konica Minolta, your complete satisfaction is our number one goal. From pre-installation through the lifetime of your investment, our professional staff provides the technical expertise you need. Project Management, Applications Training, and Field Services are different teams of Konica Minolta professionals that work together to maintain your continued satisfaction over the lifetime of your investment.

Maximize your investment in CR equipment by selecting the right Blue Moon CR Lifecycle Products and Customer Satisfaction Agreements to ensure the ongoing operational excellence and productivity that your department needs.



KONICA MINOLTA

KONICA MINOLTA MEDICAL IMAGING USA, INC.
411 NEWARK POMPTON TURNPIKE
WAYNE, NJ 07470
TEL: (973) 633-1500 FAX: (973) 523-7408
WEBSITE: medical.konicaminolta.us